

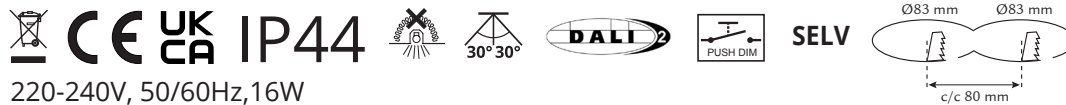

# Junistar LUX Square 2x DALI



220-240V, 50/60Hz, 16W

 <b>III</b> 36V	 <b>□</b> 350mA	
 SG Multibox SG Multibox TEK SG Multibox Mini SG Concretebox SG Sealbox SG Ledbox 48 	 IP44 IP44 IP44 IP44	 
<b>Push Dim</b> 		<b>DALI Dim</b> 
 <b>NO:</b> Skru av strømmen før montering. <b>DK:</b> Sluk for strømmen inden montering. <b>SE:</b> Stäng av strömmen innan montering. <b>EN:</b> Turn off power before installing. <b>FR:</b> Couper le courant avant l'installation. <b>NL:</b> Stroom uitschakelen voor u het toestel installeert. <b>DE:</b> Vor Installationsarbeiten den Strom abschalten. <b>FI:</b> Sammuta virta ennen kytkemistä		<b>NO:</b> Kan kun installeres og vedlikeholdes av en registrert installasjonsvirksomhet. <b>DK:</b> Må kun installeres og vedligeholdes af uddannet elektriker. <b>SE:</b> Skall installeras och underhållas av behörig elektriker. <b>EN:</b> Only to be installed and maintained by an authorized electrician. <b>FR:</b> Doit être installé et maintenu par un électricien qualifié. <b>NL:</b> Mag alleen geïnstalleerd en onderhouden worden door een bevoegde electricien. <b>DE:</b> Dieses Produkt darf nur durch autorisiertes Personal (z.B. Elektro-Installateur) angeschlossen, in Betrieb genommen und gewartet werden. <b>FI:</b> Asentaa ja huoltaa saa vain valtuutettu sähköasentaja

Rev: 26.01.2021

**NORWAY**  
 SG Armaturen AS  
 Skytterheia 25  
 N-4790 Lillesand

**SWEDEN**  
 SG Armaturen AB  
 Tel: +46 31 81 71 10  
 info@sg-ab.se  
 www.sg-ab.se

**DENMARK**  
 SG Armaturen A/S  
 Tel: +45 70 70 72 13  
 info@sg-as.dk  
 www.sg-as.dk

**FRANCE**  
 SG Lighting SA/NV  
 Tel: +33(0) 4 94 93 00 00  
 info.france@sightinging.fr  
 www.sightinging.net

**GERMANY**  
 SG Leuchten GmbH  
 Tel: +49 40 23 99 44 59  
 info@sg-leuchten.de  
 www.sg-leuchten.de

Tel: +47 37 50 03 00  
 firmapost@sg-as.no  
 www.sg-as.no

**FINLAND**  
 SG Armaturen Oy  
 Tel: +358 02 07 30 39 60  
 info@sg-oy.fi  
 www.sg-oy.fi

**UNITED KINGDOM**  
 SG Lighting LTD  
 Tel: +47 37 50 03 00  
 info@sightinging.co.uk  
 www.sightinging.co.uk

**BENELUX**  
 SG Lighting SA/NV  
 Tel: +32(0) 15 20 72 71  
 info.benelux@sightinging.net  
 www.sightinging.net

**INTERNATIONAL**  
 SG Lighting Co Ltd.  
 Tel: +86 769 88 49 20 88  
 cindy@sgdcn.com  
 www.sg-as.com

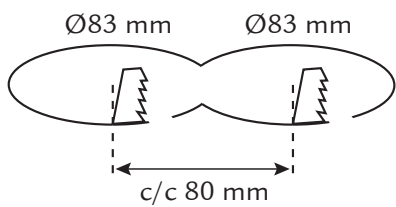
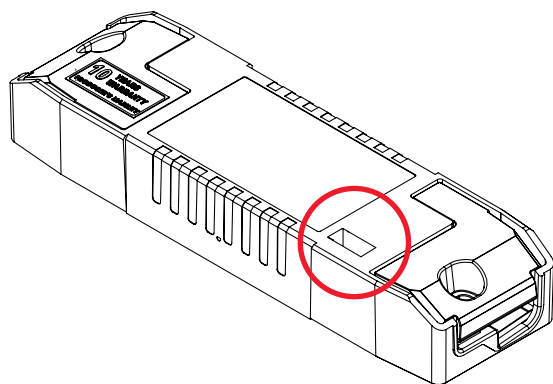
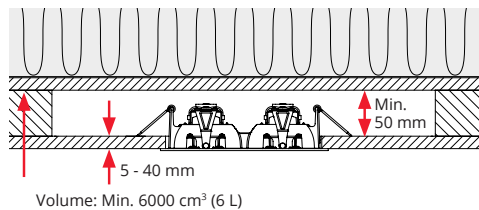

mA	Im
125	36%
150	43%
175	50%
200	57%
225	64%
250	71%
275	79%
300	86%
325	93%
<b>350</b>	<b>100%</b>
375	-
400	-
425	-
450	-
475	-
500	-



Standard



1:1

